

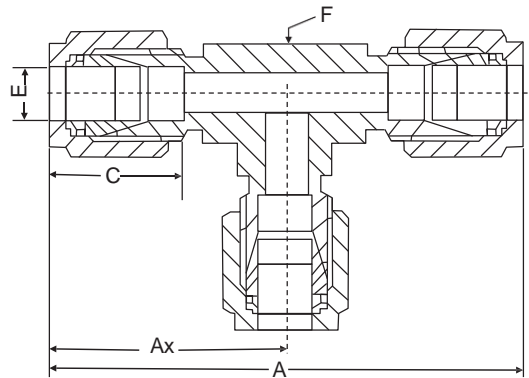

Dimensional Details :



Notes : Drawings are not to scale

**Dimensional Details**

Dimension, in.

Tube OD	Part Number	A	Ax	C	E	F
1/8	<b>STU2</b>	1.76	0.88	0.50	0.09	3/8
1/4	<b>STU4</b>	2.12	1.06	0.60	0.19	1/2
5/16	<b>STU5</b>	2.34	1.17	0.64	0.25	5/8
3/8	<b>STU6</b>	2.40	1.20	0.66	0.28	5/8
1/2	<b>STU8</b>	2.84	1.42	0.90	0.41	13/16
5/8	<b>STU10</b>	3.06	1.53	0.96	0.50	1
3/4	<b>STU12</b>	3.14	1.57	0.96	0.62	1 1/16
7/8	<b>STU14</b>	3.52	1.76	1.02	0.72	1 3/8
	<b>STU16</b>	3.86	1.93	1.23	0.88	1 3/8

Dimension, mm.

Tube OD	Part Number	A	Ax	C	E	F
6	<b>STUM6</b>	53.9	27.0	15.3	4.8	1/2
8	<b>STUM8</b>	59.7	29.9	16.2	6.4	5/8
10	<b>STUM10</b>	63.0	31.5	17.2	7.9	11/16
12	<b>STUM12</b>	72.0	36.0	22.8	9.5	13/16
16	<b>STUM16</b>	77.6	38.8	24.4	12.7	1
18	<b>STUM18</b>	79.6	39.8	24.4	15.1	1 1/16
20	<b>STUM20</b>	89.3	44.6	26.0	15.9	1 3/8
22	<b>STUM22</b>	89.3	44.6	26.0	18.3	1 3/8
25	<b>STUM25</b>	98.3	49.1	31.3	21.8	1 3/8

Dimensions and specifications shown are approximate, may vary from time to time.

Note : A and C dimensions are typical finger-tight